

MAHARASHTRA AGRICULTURAL UNIVERSITIES EXAMINATION BOARD, PUNE  
SEMESTER END EXAMINATION

B. Tech. (Agril. Engg.)

Semester	: III (New)	Term	: I	Academic Year	: 2019-20
Course No.	: IDE 231	Title	: Fluid Mechanics and Open Channel Hydraulics		
Credits	: 3(2+1)	Time	: 09.00 to 12.00	Total Marks	: 80
Day & Date	: Thursday, 14.11.2019				

- Note :
1. Solve ANY EIGHT questions from SECTION "A".
  2. All questions from SECTION "B" are compulsory.
  3. All questions carry equal marks.
  4. Draw neat diagrams wherever necessary.

SECTION "A"

- Q.1 a) Prove that the intensity of pressure at a point in a static fluid is same in all directions.  
b) What do you understand by the term most economical channel section? Estimate the maximum discharge through a rectangular channel of width 4 m, bed slope of in 1500. Assume Chezy's constant as 50.
- Q.2 a) Derive an equation for estimating discharge through venturimeter.  
b) Water flows through a triangular right-angled notch and then over a rectangular notch of 1 m width. The discharge co-efficient's of the triangular and rectangular notches is 0.6 and 0.7, respectively. If the depth of water over the triangular notch is 360 mm, find the depth of water over the rectangular notch.
- Q.3 a) What do you understand by a single column mercury manometer? Derive an equation for determination of pressure in a pipe using a vertical single column manometer.  
b) Derive Darcy-Weisbach equation for head loss due to friction in pipes.
- Q.4 a) Derive an equation for measuring fluid pressure difference between two points at different levels and containing liquid of different specific gravity using U-tube differential manometer.  
b) Find the discharge through a 20 x 10 cm venturimeter inserted in a horizontal pipe carrying oil of specific gravity 0.8, if the differential mercury manometer connected to the inlet and the throat gives a reading of 25 cm. Assume  $C_d = 0.98$ , if required.
- Q.5 a) A 30 cm pipe conveying water branches into two pipes of diameters 20 cm and 15 cm, respectively. If the average velocity in 30 cm diameter pipe is 2.5 m/s and average velocity in 20 cm diameter pipe is 2.0 m/s, find the velocity in the 15 cm diameter pipe. Also determine the discharge through each pipe.  
b) State Bernoulli's equation for steady flow of an incompressible fluid. Enlist the assumptions made for the same.
- Q.6 a) Prove that for a vertical plane surface submerged in a liquid, the center of pressure is always below the centre of gravity.  
b) A block of size 2 m long x 1 m wide x 0.8 m deep floats in water. The specific gravity of the block material is 0.7. Determine the centre of Buoyancy and meta-centric height of the floating body.

(P.T.O.)

- Q.7 a) Differentiate between geometric and kinematic similarities that must exist between the model and the prototype.  
 b) Derive an expression for discharge over a triangular notch. Hence, develop a relationship between discharge and head over the notch for a right angled V-notch. Assume  $C_d$  as 0.62.
- Q.8 Write short notes. (Any Two)  
 a) Hydraulic ram  
 b) Conditions of equilibrium of a floating body  
 b) U-tube manometer
- Q.9 a) Derive an equation for estimating efficiency of power transmission through pipes.  
 b) Calculate the capillary rise/fall in a 4 mm glass tube when immersed vertically in water. Assume the surface tension for water at  $20^\circ\text{C}$  when in contact with air to be  $0.073575 \text{ N/m}$  and its density as  $998 \text{ kg/m}^3$ .
- Q.10 a) Determine the total pressure and the position of center of pressure for a 1.5 m diameter circular plate. The center of the plate is 3 m below the free surface when placed vertically in water.  
 b) Using Darcy-Weisbach formula and Chezy's formula, find the major energy loss through the 50 m long, 300 mm diameter pipe carrying water at a velocity of 3 m/s. Assume kinematic viscosity of water as  $0.01 \times 10^{-4} \text{ m}^2/\text{s}$  and  $C=60$ .

#### SECTION "B"

- Q.11 State True or False.
- 1) The equation for loss of head due to sudden enlargement of pipe is  $h_e = \frac{(V_1 - V_2)^2}{2g}$ .
  - 2) For super critical flow in an open channel, the Froude number is  $< 1$ .
  - 3) Syphon can be used to empty a channel not provided with any outlet sluice.
  - 4) Newton's law of viscosity states that the shear stress on a fluid element is inversely proportional to the rate of shear strain.
  - 5) If the specific gravity of a fluid is known, then the density of the fluid will be equal to specific gravity of fluid multiplied by specific weight of fluid.
  - 6) Atmospheric pressure is defined as the pressure that is measured with reference to absolute vacuum pressure.
  - 7) When body is immersed in a fluid, an upward force is exerted by the fluid on the body and this upward force is equal to the weight of the fluid displaced by the body.
  - 8) The total energy line gives the sum of pressure head and velocity head of the flowing fluid in a pipe with respect to some reference line.
- Q.12 Define the following terms.
- |                                      |                            |
|--------------------------------------|----------------------------|
| 1) Coefficient of velocity ( $C_v$ ) | 2) Metacenter              |
| 3) Rapid or torrential flow          | 4) Hydraulic gradient line |
| 5) Froude's Number                   | 6) Viscosity               |
| 7) Streamtube                        | 8) Surface tension         |



MAHARASHTRA AGRICULTURAL UNIVERSITIES EXAMINATION BOARD, PUNE  
SEMESTER END EXAMINATION

B. Tech. (Agril. Engg.)

Semester	: III (New)	Term	: I	Academic Year	: 2019-20
Course No.	: AS - EXTN 231	Title	: Entrepreneurship Development and Business Communication		
Credits	: 2(1+1)	Time	: 09.00 to 11.00	Total Marks	: 40
Day & Date	: Wednesday, 13.11.2019				

- Note :
1. Solve ANY EIGHT questions from SECTION "A".
  2. All questions from SECTION "B" are compulsory.
  3. All questions carry equal marks.
  4. Draw neat diagrams wherever necessary.

SECTION "A"

- Q.1 Explain in detail SWOT analysis.
- Q.2 Define entrepreneurship and enlist characteristics of entrepreneur.
- Q.3 Write in short objectives of entrepreneurship development programme.
- Q.4 Write in detail about phases of entrepreneurship development programme.
- Q.5 Write in detail about how to generate ideas.
- Q.6 Define incubation and write in detail about incubation process.
- Q.7 Enlist contract farming and describe any one.
- Q.8 What is capital and write down in detail about profit and loss statement.
- Q.9 Define project and write in detail about discounted and undiscounted measure.
- Q.10 Write short notes (Any Two).
- a) WTO on Agriculture
  - b) Contract farming
  - c) Intellectual property right

SECTION "B"

- Q.11 State True or False.
- 1) The term Entrepreneur was coined by Richard Gary.
  - 2) Entrepreneur is derived from Greek Verb.
  - 3) Patent is tripoly right given by the government.
  - 4) Agreement on Agriculture Constitute four pillars.
- Q.12 Give full form of the following.
- 1) WTO
  - 2) TRIPS
  - 3) GATT
  - 4) SWOT





MAHARASHTRA AGRICULTURAL UNIVERSITIES EXAMINATION BOARD, PUNE  
SEMESTER END EXAMINATION

B. Tech. (Agril. Engg.)

Semester	: III (New)	Term	: I	Academic Year	: 2019-20
Course No.	: FMPE 235	Title	: Theory of Machines		
Credits	: 2(1+1)	Time	: 09.00 to 11.00	Total Marks	: 40
Day & Date	: Thursday, 07.11.2019				

- Note :
1. Solve ANY EIGHT questions from SECTION "A".
  2. All questions from SECTION "B" are compulsory.
  3. All questions carry equal marks.
  4. Draw neat diagrams wherever necessary.

SECTION "A"

- Q.1 In Whitworth quick return mechanism, if length of driving link is 400 mm, what should be the distance between the fixed pivots if the ratio of required time of forward stroke and return stroke is 2:1?
- Q.2 Why the crank and slotted lever mechanism, which is one of the inversions of single slider crank chain, is called as quick return mechanism? Justify in detail with suitable sketch.
- Q.3 State and prove the law of gearing with suitable sketch.
- Q.4 The number of teeth on each of the two equal spur gears in mesh is 40. The teeth have  $20^\circ$  involute profile and the module is 6 mm. Find the addendum, if the length of path of contact is 31 mm.
- Q.5 Derive an expression for partial balancing of unbalanced primary force in a reciprocating engine with the help of suitable sketch.

Q.6

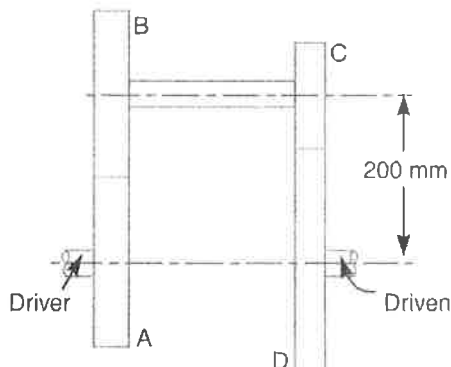

The speed ratio of the reverted gear train, as shown in figure, is to be 12. The module pitch of gears A and B is 3.125 mm and of gears C and D is 2.5 mm. Calculate the suitable numbers of teeth for the gears.

No gear is to have less than 24 teeth.

- Q.7 Derive an expression for the holding or braking torque on the fixed member of epicyclic gear trains.
- Q.8 Derive an expression for the energy stored in a flywheel.
- Q.9 A Porter governor has equal arms each 0.25 m long and pivoted on the axis of rotation. The radius of rotation of the ball is 0.15 m when the governor begins to lift and 0.2 m when the governor is at maximum speed. The central load on the sleeve weighs 30 kg which is 5 times of the mass of ball. If the mass of each ball is same, find the minimum and maximum speeds of the governor.

(P.T.O.)

- Q.10 Three masses  $m_1$ ,  $m_2$  and  $m_3$  are 50 kg, 80 kg and 120 kg, respectively. The corresponding radii of rotation are 150 mm, 200 mm and 250 mm, respectively and the angles between successive masses are  $45^\circ$  and  $75^\circ$ . Find the position and magnitude of the balance mass required by analytical method, if its radius of rotation is 180 mm.

**SECTION "B"**

- Q.11 Define the following terms.

- |                           |                                    |
|---------------------------|------------------------------------|
| 1) Inversion of Mechanism | 2) Incompletely constrained motion |
| 3) Kinematic Pair         | 4) Pressure angle                  |

- Q.12 State True or False.

- 1) Proell governor is spring loaded governor.
- 2) The function of the flywheel is to regulate the mean speed of an engine when there are variations in the load.
- 3) Backlash is the difference between the tooth space and the tooth thickness, as measured along the pitch circle.
- 4) Quaternary joint is equivalent to four binary joints.



MAHARASHTRA AGRICULTURAL UNIVERSITIES EXAMINATION BOARD, PUNE  
SEMESTER END EXAMINATION

B. Tech. (Agril. Engg.)

Semester	: III (New)	Term	: I	Academic Year	: 2019-20
Course No.	: SWCE 232	Title	: Soil Mechanics		
Credits	: 2(1+1)	Time	: 09.00 to 11.00	Total Marks	: 40
Day & Date	: Friday, 08.11.2019				

- Note :
1. Solve ANY EIGHT questions from SECTION "A".
  2. All questions from SECTION "B" are compulsory.
  3. All questions carry equal marks.
  4. Draw neat diagrams wherever necessary.

SECTION "A"

- Q.1 What is soil, soil mechanics and soil engineering? Explain the field of application of soil mechanics.
- Q.2 Derive functional relationship between  $\gamma$ , G, e and Sr.
- Q.3 A soil sample has a porosity of 40 per cent. The specific gravity of solids is 2.70, calculate:  
i) Voids ratio      ii) Dry density      iii) Unit weight, if the soil is 50 % saturated
- Q.4 Enlist methods of determination of *in-situ* density of soil. Explain in brief any one method.
- Q.5 Explain the particle size distribution curve.
- Q.6 Define compaction. Explain the standard proctor's test.
- Q.7 What are the assumptions of Terzaghi's one dimensional consolidation theory?
- Q.8 What is the purpose of soil classification? State different systems of soil classification and explain any one of them.
- Q.9 State assumptions of Rankine theory. Derive an expression of Rankine's theory of active earth pressure for Cohesionless dry and moist backfill with no surcharge.
- Q.10 Explain the stability analysis of infinite slope.

SECTION "B"

- Q.11 Define the following terms.
- 1) Degree of saturation
  - 2) Plastic limit
  - 3) Air voids line
  - 4) Compression
- Q.12 Fill in the blanks.
- 1) \_\_\_\_\_ is the numerical difference between the liquid limit and plastic limit.
  - 2) The compactive energy used for modified proctors test is \_\_\_\_\_ kg-cm per 1000 cm<sup>3</sup>.
  - 3) \_\_\_\_\_ is the change in volume of soil per unit initial volume due to a given incremental pressure.
  - 4) The position of backfill laying above the horizontal plane at the elevation of the top of a wall is called \_\_\_\_\_.



MAHARASHTRA AGRICULTURAL UNIVERSITIES EXAMINATION BOARD, PUNE  
SEMESTER END EXAMINATION

B. Tech. (Agril. Engg.)

Semester	: III (New)	Term	: I	Academic Year	: 2019-20
Course No.	: FMPE 235	Title	: Theory of Machines		
Credits	: 2(1+1)	Time	: 09.00 to 11.00	Total Marks	: 40
Day & Date	: Thursday, 07.11.2019				

- Note :
1. Solve ANY EIGHT questions from SECTION "A".
  2. All questions from SECTION "B" are compulsory.
  3. All questions carry equal marks.
  4. Draw neat diagrams wherever necessary.

SECTION "A"

- Q.1 In Whitworth quick return mechanism, if length of driving link is 400 mm, what should be the distance between the fixed pivots if the ratio of required time of forward stroke and return stroke is 2:1?
- Q.2 Why the crank and slotted lever mechanism, which is one of the inversions of single slider crank chain, is called as quick return mechanism? Justify in detail with suitable sketch.
- Q.3 State and prove the law of gearing with suitable sketch.
- Q.4 The number of teeth on each of the two equal spur gears in mesh is 40. The teeth have  $20^\circ$  involute profile and the module is 6 mm. Find the addendum, if the length of path of contact is 31 mm.
- Q.5 Derive an expression for partial balancing of unbalanced primary force in a reciprocating engine with the help of suitable sketch.

Q.6

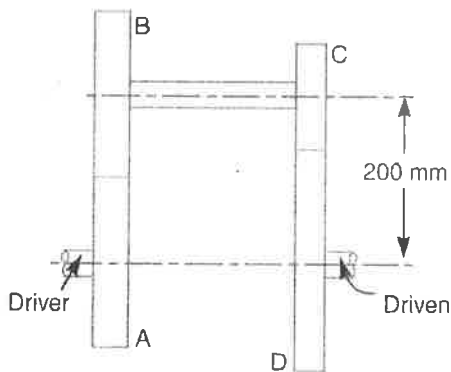

The speed ratio of the reverted gear train, as shown in figure, is to be 12. The module pitch of gears A and B is 3.125 mm and of gears C and D is 2.5 mm. Calculate the suitable numbers of teeth for the gears.

No gear is to have less than 24 teeth.

- Q.7 Derive an expression for the holding or braking torque on the fixed member of epicyclic gear trains.
- Q.8 Derive an expression for the energy stored in a flywheel.
- Q.9 A Porter governor has equal arms each 0.25 m long and pivoted on the axis of rotation. The radius of rotation of the ball is 0.15 m when the governor begins to lift and 0.2 m when the governor is at maximum speed. The central load on the sleeve weighs 30 kg which is 5 times of the mass of ball. If the mass of each ball is same, find the minimum and maximum speeds of the governor.

(P.T.O.)

Q.10 Three masses  $m_1$ ,  $m_2$  and  $m_3$  are 50 kg, 80 kg and 120 kg, respectively. The corresponding radii of rotation are 150 mm, 200 mm and 250 mm, respectively and the angles between successive masses are  $45^\circ$  and  $75^\circ$ . Find the position and magnitude of the balance mass required by analytical method, if its radius of rotation is 180 mm.

**SECTION "B"**

Q.11 Define the following terms.

- |                           |                                    |
|---------------------------|------------------------------------|
| 1) Inversion of Mechanism | 2) Incompletely constrained motion |
| 3) Kinematic Pair         | 4) Pressure angle                  |

Q.12 State True or False.

- 1) Proell governor is spring loaded governor.
- 2) The function of the flywheel is to regulate the mean speed of an engine when there are variations in the load.
- 3) Backlash is the difference between the tooth space and the tooth thickness, as measured along the pitch circle.
- 4) Quaternary joint is equivalent to four binary joints.



**MAHARASHTRA AGRICULTURAL UNIVERSITIES EXAMINATION BOARD, PUNE**  
**SEMESTER END EXAMINATION**

**B. Tech. (Agril. Engg.)**

<b>Semester</b> : III (New)	<b>Term</b> : I	<b>Academic Year</b> : 2019-20
<b>Course No.</b> : BS-MATH 233	<b>Title</b> : Engineering Mathematics-III	
<b>Credits</b> : 3(2+1)	<b>Time</b> : 09.00 to 12.00	<b>Total Marks</b> : 80
<b>Day &amp; Date</b> : Monday, 04.11.2019		

- Note :**
1. Solve ANY EIGHT questions from SECTION "A".
  2. All questions from SECTION "B" are compulsory.
  3. All questions carry equal marks.
  4. Draw neat diagrams wherever necessary.

**SECTION "A"**

- Q.1 a) From the following table, estimate the number of students who obtained marks between 40 and 45:

Marks :	30-40	40-50	50-60	60-70	70-80
No. of students :	31	42	51	35	31

- b) In the following table, the values of y are consecutive terms of a series of which 23.6 is the 6<sup>th</sup> term. Find the first and tenth terms of the series.

x :	3	4	5	6	7	8	9
y :	4.8	8.4	14.5	23.6	36.2	52.8	73.9

- Q.2 a) A curve passes through the point (0,18), (1,10), (3,-18) and (6,90) find the slope of the curve at  $x = 2$

b) Given that

x :	1.0	1.1	1.2	1.3	1.4	1.5	1.6
y :	7.989	8.403	8.781	9.129	9.451	9.750	10.031

Find  $\frac{dy}{dx}$  at  $x = 1.1$

- Q.3 a) Find the maximum and minimum value of y from the following data:

x :	-2	-1	0	1	2	3	4
y :	2	-0.25	0	-0.25	2	15.75	56

- b) Use the Trapezoidal rule to estimate the integral  $\int_0^2 e^{x^2} dx$  by taking ten intervals.

**(P.T.O.)**

- Q.4 a) By using Simpson's 1/3<sup>rd</sup> rule to find  $\int_0^{0.6} e^{-x^2} dx$  by taking seven ordinates.
- b) Compute the value of  $\int_{0.2}^{1.4} (\sin x - \log x + e^x) dx$  using Simpson's 3/8<sup>th</sup> rule.
- Q.5 a) Solve :  $y_{n+2} - 4y_{n+1} + 3y_n = 5^n$
- b) Solve :  $y_{n+2} - 2y_{n+1} \cos \alpha + y_n = \cos \alpha n$
- Q.6 a) Solve :  $y_{n+2} - 2y_{n+1} + y_n = n^2 2^n$
- b) Find the value of y for x = 0.1 by Picard's method, given that  $\frac{dy}{dx} = \frac{y-x}{y+x}$ ,  $y(0) = 1$
- Q.7 a) State and prove First shifting property.
- b) Find the Laplace transform of the function.
- $$f(t) = E \sin wt, \quad 0 < t < \Pi/w$$
- $$= 0, \quad \Pi/w < t < 2\Pi/w$$
- Q.8 a) Find the Laplace transform of  $\frac{\cos at - \cos bt}{t}$
- b) Find the inverse Laplace transform of  $\frac{s+2}{s^2 - 4s + 13}$
- Q.9 a) Find the inverse Laplace transform of  $\log \frac{s+1}{s-1}$
- b) Apply Convolution theorem to evaluate  $L^{-1} \left[ \frac{s}{(s^2 + a^2)^2} \right]$
- Q.10 The small oscillations of a certain system with two degrees of freedom are given by the equations:
- $$D^2x + 3x - 2y = 0$$
- $$D^2x + D^2y - 3x + 5y = 0$$
- Where  $D = \frac{d}{dt}$ . if  $x = 0, y = 0, x = 3, y = 2$  when  $t = 0$ , find x and y when  $t = \frac{1}{2}$

## SECTION "B"

- Q.11 Define the following terms.
- |                                  |                                   |
|----------------------------------|-----------------------------------|
| 1) First forward difference      | 2) Shift Operator E               |
| 3) Averaging operator ( $\mu$ )  | 4) Laplace transform              |
| 5) Linearity property            | 6) Order of a difference equation |
| 7) Simpson's 1/3 rd rule formula | 8) Trapezoidal rule formula       |

Q.12 Fill in the blanks.

1) A product of the form  $x(x-1)(x-2)(x-3)\dots(x-r+1)$  is denoted by  $[x]^r$  and is called \_\_\_\_\_.

2)  $L(e^{at}) =$  \_\_\_\_\_.

3) Inverse Laplace transform of  $(s+2)^{-2} =$  \_\_\_\_\_.

4)  $L[\cos(2t+3)] =$  \_\_\_\_\_.

5) The solution of  $y_{n-2} - 4y_{n-1} + 4y_n = 0$  is \_\_\_\_\_.

6) The complimentary function of the equation  $y_{n-2} - 2y_{n-1} + y_n = 0$  is = \_\_\_\_\_.

7) Simpson's 3/8<sup>th</sup> rule  $\int_{x_0}^{x_0+nh} f(x) dx =$  \_\_\_\_\_.

8) The process of evaluating a definite integral from a set of tabulated values of the integrand  $f(x)$  is called \_\_\_\_\_.





**MAHARASHTRA AGRICULTURAL UNIVERSITIES EXAMINATION BOARD, PUNE**  
**SEMESTER END EXAMINATION**

**B. Tech. (Agril. Engg.)**

<b>Semester</b> : III (New)	<b>Term</b> : I	<b>Academic Year</b> : 2019-20
<b>Course No.</b> : SWCE 233	<b>Title</b> : Watershed Hydrology	
<b>Credits</b> : 3(2+1)	<b>Time</b> : 09.00 to 12.00	<b>Total Marks</b> : 80
<b>Day &amp; Date</b> : Wednesday, 06.11.2019		

- Note :**
1. Solve ANY EIGHT questions from SECTION "A".
  2. All questions from SECTION "B" are compulsory.
  3. All questions carry equal marks.
  4. Draw neat diagrams wherever necessary.

**SECTION "A"**

- Q.1 a) What are the causes for failure of levee?  
b) What is flood routing? Explain basic equation for flood routing.
- Q.2 a) A basin has an area of 26560 km<sup>2</sup>, perimeter 965 km and length of basin 230 km.  
Determine; Form factor, compactness coefficient, Elongation ratio and Circulatory ratio.  
b) Explain in brief Cook's method.
- Q.3 a) Enlist the components of hydrograph. Explain any one.  
b) Explain in brief the main characteristics of semi arid regions.
- Q.4 a) Explain with the help of neat sketch the hydrologic cycle in nature, indicating its various phases.  
b) Describe various forms of precipitation.
- Q.5 a) Enlist methods of determining the mean areal depth and explain Isohyetal method.  
b) Explain the factors affecting evaporation rate from water surface.
- Q.6 a) A catchment has six rain gauge stations. In a year, the annual rainfall recorded by the gauges are as follows:

Stations	A	B	C	D	E	F
Rainfall	82.6	102.9	108.3	110.3	98.8	136.7

For a 10% error in the estimation of the mean rainfall. Calculate the optimum number of stations in the catchment.

- b) The average annual rainfall of the station A,B,C, and D are 70,85,75 and 90 cm, respectively. Rain gauge station 'D' was inoperative during a storm occurred. The storm rainfall recorded in the surrounding station A,B and C is 8.5,6.7 and 9.0 cm, respectively. Estimate the storm rainfall at station D.
- Q.7 a) The following are the ordinates of a 3-hr unit hydrograph. Derive the ordinates of 6 hr unit hydrograph.

Time (hr) :	0	3	6	9	12	15	18	21	24	27
3-hr UG (cumec)	0	2.1	2.7	5.6	9.5	9.2	3.5	2.1	0.5	0

- b) Enumerate the steps of derivation of dimensionless unit hydrograph.

**(P.T.O.)**

- Q.8 a) Describe Rational formula.  
 b) Explain the factors affecting runoff.
- Q.9 a) Estimate the peak rate of runoff of 35 years frequency for a 25 ha watershed in medium black soil having 15,5 and 5 ha under cultivation ( $C = 0.7$ ), forest ( $C = 0.4$ ) and grass land ( $C = 0.2$ ), respectively, Maximum length of run is aprox. 2300 m and most remote point is 50 m below the farthest point. Values of  $K$ ,  $a$ ,  $b$ ,  $n$  are 7.4674, 0.1712, 0.75 and 0.9599, respectively.  
 b) Describe elements of Unit Hydrograph.
- Q.10 Derive the ordinates of unit hydrograph from the runoff data collected from 500 km<sup>2</sup> watershed at 3-hr interval. Assume the base flow = 20 m<sup>3</sup>/s.

Time (hr)	0	3	6	9	12	15	18
Runoff (m <sup>3</sup> /s)	20	120	400	350	175	100	20

#### SECTION "B"

- Q.11 Fill in the blanks.
- 1) The standard Symons type raingauge has a collecting area of diameter \_\_\_\_\_ cm.
  - 2) The storm of unit duration i.e. duration of unit hydrograph regardless of its intensity is called \_\_\_\_\_ storm.
  - 3) In India, a meteorological subdivision is considered to be affected by \_\_\_\_\_ drought if it receives a total seasonal rainfall which is between 50% to 74% of normal value.
  - 4) The average pan coefficient for the standard US Weather Bureau Class A pan is \_\_\_\_\_.
  - 5) A \_\_\_\_\_ cyclone is a zone of low pressure with anticlockwise wind in the Northern hemisphere.
  - 6) The hydrologic equation states that the difference between flow and outflow is \_\_\_\_\_.
  - 7) \_\_\_\_\_ is a plot of stream discharge against time.
  - 8) The chemical that is found to be most suitable as water evaporation inhibitor is \_\_\_\_\_.
- Q.12 State True or False.
- 1) A stilling well is require when the stage measurement is made by employing a float gauge recorder.
  - 2) The hydrologic cycle occurs continuously in nature.
  - 3) Tipping type rain gauge does not produce the mass curve of precipitation as record.
  - 4) Isohyet is a line joining points having equal rainfall depth in a given duration.
  - 5) A mass curve of rainfall need not always be a rising curve.
  - 6) A unit hydrograph has one unit of direct runoff.
  - 7) The hydrologic flood routing methods use equation of continuity.
  - 8) The science and practice of water flow measurement is known as hydrometry.



MAHARASHTRA AGRICULTURAL UNIVERSITIES EXAMINATION BOARD, PUNE.  
SEMESTER END EXAMINATION  
B.Tech (Agril.Engg.)

Semester : III (OLD)	Academic year : 2019-2020
Course No. : EOES-233	Course Title: Electrical Circuits
Credits : 3(2+1)	Total Marks : 80
Day & Date : THU 14.11.2019	Time : 3 hours 14.00 - 17.00

- Note: 1. Solve ANY EIGHT question from SECTION "A"  
2. All questions from SECTION "B" are compulsory.  
3. All questions carry equal marks.  
4. Draw neat diagrams wherever necessary.

SECTION "A"

- Q.1 a) State and explain Maximum Power Transfer Theorem (4)  
b) State and explain Superposition theorem. (4)
- Q.2 a) What are the different equipments used for improvement of power factor , explain them in brief. (4)  
b) The potential difference measured across a coil is 4.5 V , when it carries a direct current of 9 A . The same coil when carries an alternating current of 9 A at 25 Hz, the potential difference is 24 V. Find the current, the power and power factor when it is supplied by 50 V , 50Hz supply. (4)
- Q.3 Write a detail note on Root-Mean -Square Value. (8)
- Q.4 a) Derive the equation for alternating voltage and current and prove that  $e = 2 \pi f N B_m A \sin \omega t$ . (4)  
b) Describe in detail the mesh analysis method using matrix form with neat diagram. (4)
- Q.5 a) A balanced star connected load of  $(8 + j6) \Omega$  per phase is connected to balanced 3- phase 400-V supply. Find the line current, power factor, power and total volt-amperes. (4)  
b) An alternating current of frequency 60 Hz has a maximum value of 120 A. Write down the equation for its instantaneous value . Reckoning time from the instant the current is zero and is becoming positive. Find a) the instantaneous value after  $1/360$  second and b) the time taken to reach 96 A for the first time. (4)

- Q.6 a) Explain in brief i) Reactive Power ii) Apparent power.  
 b) Explain delta /star transformation with neat diagram.
- Q.7 a) What are the disadvantages of low power factor?  
 b) Derive an expression for voltages, currents and power in star connection of poly phase circuits.
- Q.8 What are the different methods used to measure three phase power , explain any one of them in detail.
- Q.9 Draw and explain working of staircase and go-down wiring.
- Q.10 Write a short note on independent and dependent voltage and current sources .

### SECTION "B"

- Q.11 **Define**
- |                    |                       |
|--------------------|-----------------------|
| 1) Passive network | 2) Active network     |
| 3) Phase sequence  | 4) Amplitude          |
| 5) Linear circuit  | 6) Non-linear circuit |
| 7) Frequency       | 8) Node               |
- Q.12 **State True or False**
- 1) Inductive reactance is given by formula  $X_L = 4\pi fL$
  - 2) In case of delta connection  $I_L = \sqrt{3} I_{ph}$ .
  - 3) In case of delta connection  $V_L = V_{ph}$ .
  - 4) In case of three phase circuit power  $P = \sqrt{3} V_L I_L \tan \phi$  .
  - 5) The voltages induced in the three windings of a 3-phase alternator are 90 degree apart in the time phase.
  - 6) In Thevenins theorem ,while calculating  $R_{th}$  constant-current sources in the circuit are replaced by 'shorts'.
  - 7) The voltage applied across an R-L circuit is equal to algebraic sum of  $V_R$  and  $V_L$
  - 8) A leading alternating quantity is one which achieves its maximum or zero value first.

MAHARASHTRA AGRICULTURAL UNIVERSITIES EXAMINATION BOARD, PUNE  
SEMESTER END EXAMINATION

B.Tech. (Agril. Engg.)

Semester : III (Old) Academic year : 2019-2020  
Course No. : BS-STAT-237 Course Title : Statistical Methods  
Credits : 2 (1+1) Total Marks : 40  
Day & Date : WED 13.11.2019 Time : 14.00 - 16.00

- Note : 1. Solve ANY EIGHT question from SECTION "A"  
2. All questions from SECTION "B" are compulsory.  
3. All questions carry equal marks.  
4. Draw neat diagrams wherever necessary.

SECTION "A"

- Q.1) Define and state the formula of Mean and Median for continuous frequency distribution.
- Q.2) Explain the absolute and relative measure of dispersion.
- Q.3) Define Karl Pearson's coefficient of correlation between X and Y and state its formula. Explain Spearman's rank correlation coefficient in brief.
- Q.4) Explain clearly the procedure generally followed in testing of hypothesis.
- Q.5) Define normal distribution. State the properties of normal distribution.
- Q.6) State and prove the addition laws of probability.
- Q.7) Explain the term 'Analysis of Variance'. State the basic assumptions in the analysis of variance.
- Q.8) What do you mean by classification? Explain the qualitative and quantitative classification.
- Q.9) Explain the Chi-square test for goodness of fit.
- Q.10) Write short notes.  
a) Skewness      b) Frequency curve

SECTION "B"

- Q.11) Fill in the blanks.  
1) The value of variance is always ----- .  
2) The ----- distribution is also known as Gaussian distribution.  
3) Probability can never be greater than ----- .  
4) Histogram can be drawn only for ----- distribution.
- Q.12) State True or False.  
1) In case of positively skew distribution mode < median < mean.  
2) Population census result is a classical example of secondary data.  
3) The harmonic mean of n observations is the reciprocal of the arithmetic mean of the reciprocals of the numbers.  
4) The difference between maximum and minimum values in the series is known as standard deviation.

MAHARASHTRA AGRICULTURAL UNIVERSITIES EXAMINATION BOARD, PUNE  
SEMESTER END EXAMINATION

B. Tech. (Agril. Engg.)

Semester	: III (Old)	Academic year	: 2019-20
Course No.	: SWCE-232	Title	: Soil Mechanics
Credit	: 3 (2+1)	Total Marks	: 80
Day & Date	: FRI 8.11.2019	Time	: 14.00 - 17.00

- NOTE : 1. Solve ANY EIGHT questions from SECTION "A"  
2. All questions from SECTION "B" are compulsory.  
3. All questions carry equal marks.  
4. Draw neat diagrams wherever necessary.

SECTION "A"

- Q.1 a) Derive the relationship between  $\gamma_d$ , G and e (4)  
b) What is soil, soil mechanics and soil engineering? Explain the field of application of soil mechanics. (4)
- Q.2 a) Enlist different methods for water content determination of soil sample and explain any one method. (4)  
b) A soil sample has a porosity of 40 percent. The specific gravity of solids is 2.70, calculate:  
i) Voids ratio, ii) Dry density, iii) Unit weight, if the soil is 50% saturated. (4)
- Q.3 An undisturbed saturated specimen of clay has a volume of  $18.9 \text{ cm}^3$  and a mass of 30.2 gm, on oven drying the mass reduces to 18.0 gm. The volume of dry specimen as determined by displacement of mercury is  $9.9 \text{ cm}^3$ . Determine: i) Shrinkage limit, ii) Specific gravity, iii) Shrinkage ratio, iv) Volumetric shrinkage. (8)
- Q.4 Define the process of compaction. Enlist different tests of compaction to find water density relationships. Explain any one method. (8)
- Q.5 a) In order to determine the water content, 370 gm of wet sandy soil sample was placed in a Pycnometer. The mass of Pycnometer, sand and water full to the top of the conical cap was found to be 2148 gm, The mass of Pycnometer full of clean water was 1932 gm. Take  $G = 2.65$ , determine the water content of the sample. (4)  
b) Explain the particle size distribution curve. (4)
- Q.6 a) Define permeability. Derive expression for average permeability of soil deposit parallel to bedding planes. (4)  
b) Enlist factors affecting Permeability. Explain any one factor. (4)
- Q.7 a) What is the purpose of soil classification? State different systems of soil classification and explain any one of them. (4)  
b) Explain the Textural classification of soil. (4)
- Q.8 Define shrinkage ratio. Derive the relation between the shrinkage ratio & mass specific gravity of soil in its dry state. (8)
- Q.9 State assumptions of Rankine theory. Derive an expression of Rankine's theory of active earth pressure for Cohesionless dry and moist backfill with no surcharge. (8)

**Maharashtra Agricultural Universities Examination Board Pune**  
**SEMESTER END THEORY EXAMINATION**  
**B.Tech. (Agril. Engg.)**

Semester – III (Old)  
 Course No. – BS-MATH-236  
 Credits : 3 (2+1)  
 Day & Date : ~~Mon~~ - 04.11.2019

Academic Year : 2019-2020  
 Title : Engineering Mathematics - III  
 Total Marks : 120  
 Time : 14.00 - 17.00

**NOTE -**

1. Solve ANY EIGHT Questions from SECTION "A"
2. All Questions from SECTION "B" are compulsory
3. All Questions carry equal marks.
4. Draw neat diagrams wherever Necessary.

**SECTION "A"**

Q.1: A) Find the laplace transform of i)  $\cos^2(2t)$  and ii)  $\sin^3(2t)$

B) Find the inverse laplace transform of  $\frac{1}{(s^2+1)(s^2+9)}$

Q.2: A) Find the laplace transform of i)  $t^2 \sin at$  and ii)  $t^3 e^{-3t}$

B) Find the inverse laplace transform of  $\log \frac{s^2+1}{s(s+1)}$

Q.3 A) Find the inverse laplace transform of  $\frac{(s+2)}{(s^2+4s+5)^2}$

B) Show that  $L(t \sin at) = \frac{2as}{(s^2+a^2)^2}$

Q.4: A) Find the inverse laplace transform of  $\frac{5}{(s^2+a^2)^2}$

B) The following table gives the viscosity of an oil as a function of temperature Use Lagrange's formula to find viscosity of oil at a temperature of  $140^\circ$

Temp <sup>o</sup>	110	130	160	190
Viscosity	10.8	8.1	5.5	4.8

Q.5: A) In the following table, the values of y are consecutive terms of a series of which 12.5 is the 5<sup>th</sup> term.

find the first and tenth terms of the series

x :	3	4	5	6	7	8	9
y :	2.7	6.4	12.5	21.6	34.3	51.2	72.9

B) Find the number of men getting wages below Rs.15 from the following data

Wages in Rs.	10	20	30	40
Frequency	9	39	74	116

Q.6: A) Find the first and second derivatives of the function tabulated below, at the point  $x=1.5$

x	1.5	2.0	2.5	3.0	3.5	4.0
F(x)	3.375	7.000	13.625	24.000	38.875	59.000

B) Using the following data, find x for which y is minimum and find this value of y.

x	0.60	0.65	0.70	0.75
y	0.6221	0.6155	0.6138	0.6170

Q.7 A) Use Simpson's 1/3<sup>rd</sup> rule to find  $\int_0^{0.6} e^{-x^2} dx$  by taking seven ordinates

B) Evaluate  $\int_0^a \frac{dx}{1+x^2}$  by using i) Trapezoidal rule ii) Simpson's 1/3<sup>rd</sup> rule iii) Simpson's

3/8<sup>th</sup> rule

Q.8: A) Given the values

X	5	7	11	13	17
F(x)	150	392	1452	2366	5202

Evaluate f(9), using Lagrange's formula

B) Solve:  $y_{n+2} - 4y_{n+1} + 3y_n = 5^n$

Q.9: A) Solve:  $y_{n+2} - 2y_{n+1} \cos \alpha + y_n = \cos \alpha n$

B) Solve:  $y_{n+2} - 2y_{n+1} + y_n = n^2 2^n$

Q.10 A) Find the value of y for x = 0.1 by Picard's method, given that  $\frac{dy}{dx} = \frac{y-x}{y+x}$ , y(0) = 1

B) Find by Taylor's series method the value of y at x = 0.1 and x = 0.2 to five places of decimals from  $\frac{dy}{dx} = x^2 y - 1$ , y(0) = 1

### SECTION "B"

Q.11 Define / State :

- |                             |  |
|-----------------------------|--|
| 1) Transforms of derivative | 7) Shift operator E                          |
| 2) Transforms of Integrals  | 8) Averaging operator                        |
| 3) Multiplication by $t^n$  | 9) Factorial notation                        |
| 4) Division by t            | 10) Lagrange's formula for unequal intervals |
| 5) Convolution theorem      | 11) Numerical integration                    |
| 6) Laplace transform        | 12) A Difference equation                    |

Q.12 Fill in the blanks :

- |   |   |
|---|---|
| 1) Interpolation is the technique of estimating the value of a function for any intermediate value of the ..... | 7) $L^{-1} \left[ \frac{s}{s^2 - (10)^2} \right] = \dots$ |
| 2) Newton's backward interpolation formula is $y_p = \dots$   | 8) $L(e^{4t}) = \dots$                                    |
| 3) Order of a difference equation .....   | 9) $L(\sin 7t) = \dots$                                   |
| 4) The complimentary function of the equation $y_{n+2} - 2y_{n+1} + y_n = 0$ is .....                           | 10) $L(\cos 3t) = \dots$                                  |
| 5) The particular integral of the equation $y_{n+2} - 4y_{n+1} + 3y_n = 5^n$ is .....                           | 11) $L(e^{3t} \sin 2t) = \dots$                           |
| 6) $L \left[ \frac{1}{s-9} \right] = \dots$   | 12) $L(\cosh 4t) = \dots$                                 |

SEMESTER END EXAMINATION

Semester	:	III	Academic year	:	2019-20
Course No.	:	FMP-236 (Old)	Title	:	Farm power
Credits	:	2(1+1)			
Day & date	:	WED 06.11.2019	Time	14.00-16.00	Total Marks: 40
Note :	1. Solve any eight questions from section A 2. All questions in section B are compulsory 3. All questions carry equal marks 4. Draw neat figures wherever necessary				

SECTION "A"

- Q1 A Explain the working of oil bath type air cleaner with neat diagram.  
 B What is resistance to carbon formation in respect of oil properties? Discuss in brief.
- Q2 What are the assumptions of Otto cycle? Derive the expression of efficiency of Otto cycle and notations. Explain how the theoretical cycle differs from actual one with help of diagram.
- Q3 A What is the difference between CI and SI engine (any four points)?  
 B What do you mean by mean effective pressure? Explain pressure increases in different strokes with the help of indicator diagram
- Q4 What is carburetion? Explain the working of carburetor with the help of neat sketch.
- Q5 Describe valve timing diagram in 4 stroke diesel engine
- Q6 State the names and function of different components the fuel supply system of tractor. Draw neat sketch.
- Q7 Explain the principle of working centrifugal type governor in spark ignition engine with neat sketch.
- Q8 Describe the working of 4 stroke diesel engine
- Q9 A six cylinder 4 stroke engine has bore dia 11 cm and stroke length 12.2 cm running at 2800 rpm consumes 455 m<sup>3</sup> air per hour. Find volumetric efficiency of engine
- Q 10 Calculate compression ratio and clearance volume of an engine whose dimensions are 100 x 120 mm and length of clearance space at top dead centre is 8 mm only.

"SECTION B"

- Q. 11 Define the following
- i) Top dead centre
  - ii) Firing interval
  - iii) Thermal efficiency
  - iv) Swept volume

Q. 12 Match the pairs

- |   |                           |                          |
|---|---------------------------|--------------------------|
| 1 | Tappet clearance          | e 2 kg/cm <sup>2</sup>   |
| 2 | FI pump pressure          | b 160 kg/cm <sup>2</sup> |
| 3 | Compression pressure      | a 35 kg/cm <sup>2</sup>  |
| 4 | Lubrication pump pressure | d 0.20 mm                |
|   |                           | e Injector               |

MAHARASHTRA AGRICULTURAL UNIVERSITIES EXAMINATION BOARD, PUNE.  
SEMESTER END EXAMINATION  
B.Tech (Agril.Engg.)

Semester	: III (OLD)	Academic year	: 2019-2020
Course No.	: EOES-233	Course Title:	Electrical Circuits
Credits	: 3(2+1)	Total Marks	: 80
Day& Date	: THU 14.11.2019	Time	: 3 hours 14.00 - 17.00

- Note: 1.Solve ANY EIGHT question from SECTION "A"  
2. All questions from SECTION "B" are compulsory.  
3.All questions carry equal marks.  
4.Draw neat diagrams wherever necessary.

SECTION "A"

- Q.1 a) State and explain Maximum Power Transfer Theorem (4)  
b) State and explain Superposition theorem. (4)
- Q.2 a) What are the different equipments used for improvement of power factor , explain them in brief. (4)  
b) The potential difference measured across a coil is 4.5 V , when it carries a direct current of 9 A . The same coil when carries an alternating current of 9 A at 25 Hz, the potential difference is 24 V. Find the current, the power and power factor when it is supplied by 50 V , 50Hz supply. (4)
- Q.3 Write a detail note on Root-Mean -Square Value . (8)
- Q.4 a) Derive the equation for alternating voltage and current and prove that  $e = 2 \pi f N B_m A \sin \omega t$ . (4)  
b) Describe in detail the mesh analysis method using matrix form with neat diagram. (4)
- Q.5 a) A balanced star connected load of  $(8 + j6) \Omega$  per phase is connected to balanced 3- phase 400-V supply. Find the line current, power factor, power and total volt-amperes. (4)  
b) An alternating current of frequency 60 Hz has a maximum value of 120 A. Write down the equation for its instantaneous value . Reckoning time from the instant the current is zero and is becoming positive. Find a) the instantaneous value after 1/360 second and b) the time taken to reach 96 A for the first time. (4)

- Q.6 a) Explain in brief i) Reactive Power ii) Apparent power.  
 b) Explain delta /star transformation with neat diagram.
- Q.7 a) What are the disadvantages of low power factor?  
 b) Derive an expression for voltages, currents and power in star connection of poly phase circuits.
- Q.8 What are the different methods used to measure three phase power , explain any one of them in detail.
- Q.9 Draw and explain working of staircase and go-down wiring.
- Q.10 Write a short note on independent and dependent voltage and current sources .

### SECTION "B"

Q.11

**Define**

- |                    |                       |
|--------------------|-----------------------|
| 1) Passive network | 2) Active network     |
| 3) Phase sequence  | 4) Amplitude          |
| 5) Linear circuit  | 6) Non-linear circuit |
| 7) Frequency       | 8) Node .             |

Q.12

**State True or False**

- 1) Inductive reactance is given by formula  $X_L = 4\pi fL$
- 2) In case of delta connection  $I_L = \sqrt{3} I_{ph}$ .
- 3) In case of delta connection  $V_L = V_{ph}$ .
- 4) In case of three phase circuit power  $P = \sqrt{3} V_L I_L \tan \phi$  .
- 5) The voltages induced in the three windings of a 3-phase alternator are 90 degree apart in the time phase.
- 6) In Thevenins theorem ,while calculating  $R_{th}$  constant-current sources in the circuit are replaced by 'shorts'.
- 7) The voltage applied across an R-L circuit is equal to algebraic sum of  $V_R$  and  $V_L$
- 8) A leading alternating quantity is one which achieves its maximum or zero value first.